



**HKM  
FANS**



# WM-78

Wall Mount Industrial Fan (Water Proof)

## AirOne Series

Air supply distance far beyond 24 meters



①

Beam bottom positioning installation



②

Pillar positioning installation

## AirOne Series

### Product Introduction

AirOne Series is the latest high-volume fan developed by HKM & factory; the installation method can be ceiling, wall-mounted, with a total height of 2m, and can be oriented according to the onsite requirements. The fan blades are driven by PMSM permanent magnet synchronous motors to output large and stable air volume; In the sweltering and irritating environment of the hot summer, AirOne can bring the cooling effect equivalent to more than 20 small fans; the overall steel frame design of the fan is sturdy and durable, and can be applied to most complicated environment places.



## »» AirOne Series

- Super air volume
- Directional air supply
- Energy saving
- Quiet and low noise
- Stepless speed regulation
- Water and dust proof

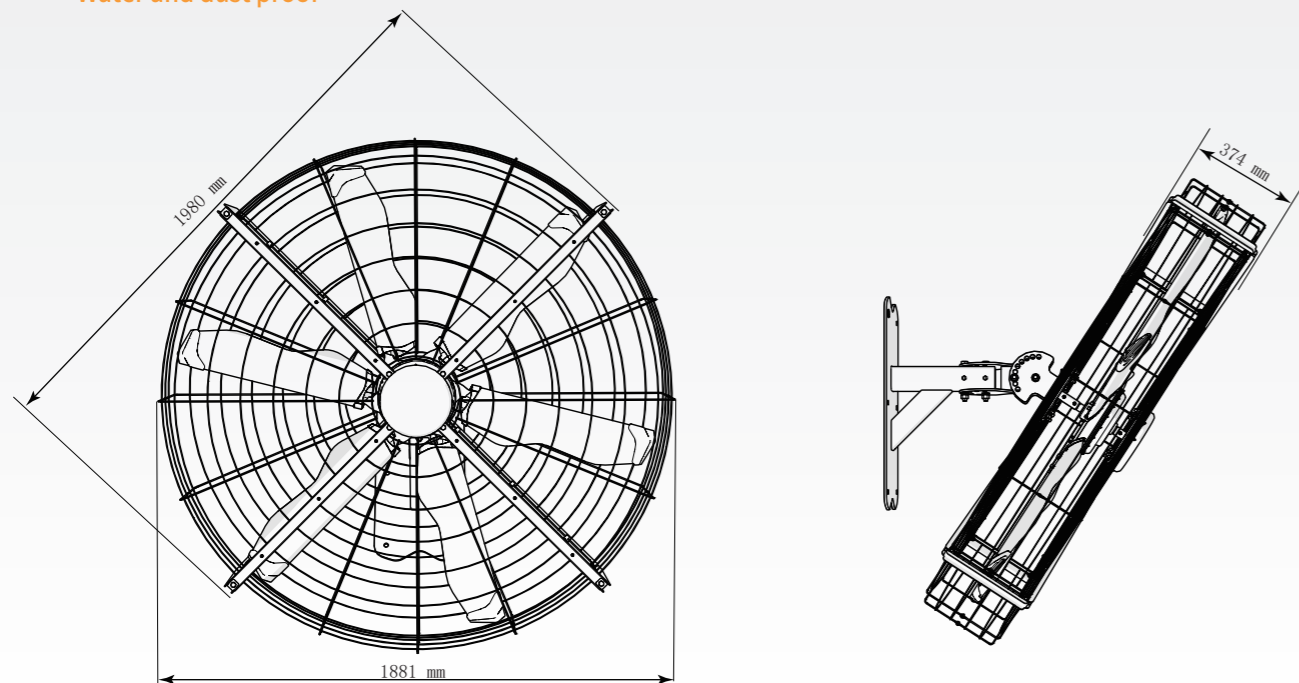

### Technical Specifications

Model	WM-78
Dimensions(WxHxD)	1980mm x 1881mm x 374mm
Max speed	320r/min
Range of wind speeds	0-36m (wind speeds 7m/s- 1.5m/s)
Full load air volume	1208m <sup>3</sup> /min
Motor	PMSM Motor
Motor Power	0.55kW
Inner Power	220V
Full-load current	1.7 A
Sound Level(maximum speed)	43dBA
Protection levels	IP55
Wight	136KG

以籃球場作對比參考/basketball court

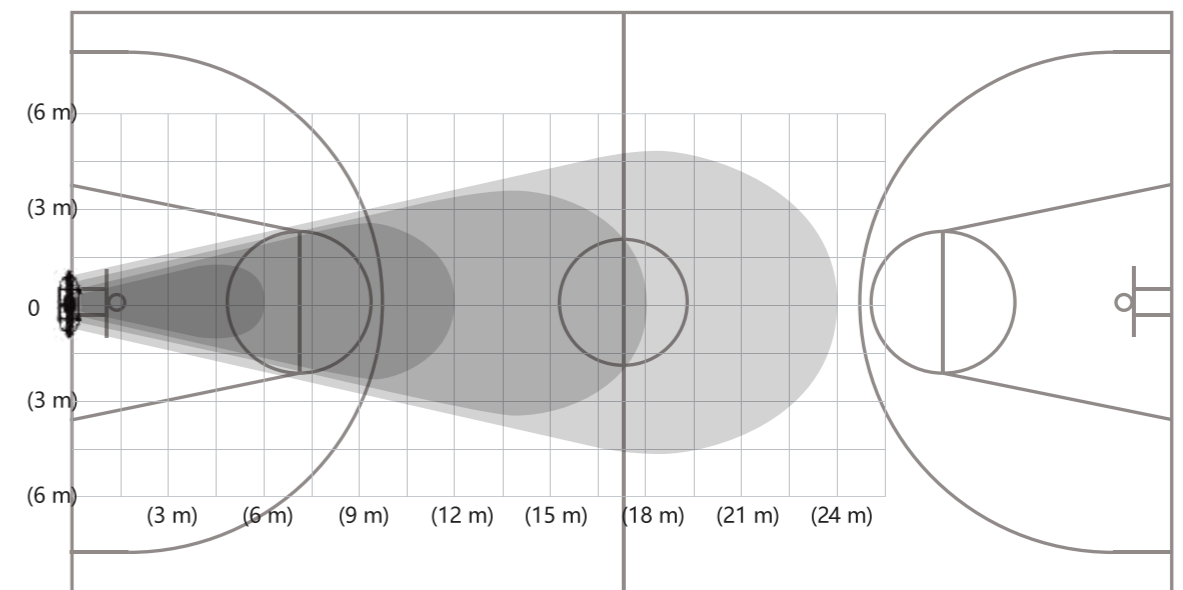

**HKM**  
**FANS**

- 5503 8458
- Admin@hkmisting.com
- hkmisting.com

Application case

